

 **STERIVALVES**  
Process Advantage

FEEDING  
**ROTOVALVE LIGHT**

Rotovalve Light is part of the modular system (see Modular System sheet). This valve is designed to feed and continuously control the discharged flow. Thanks to rotary alternating motion, it helps the product to be discharged homogeneously.

SEZIONE A-A

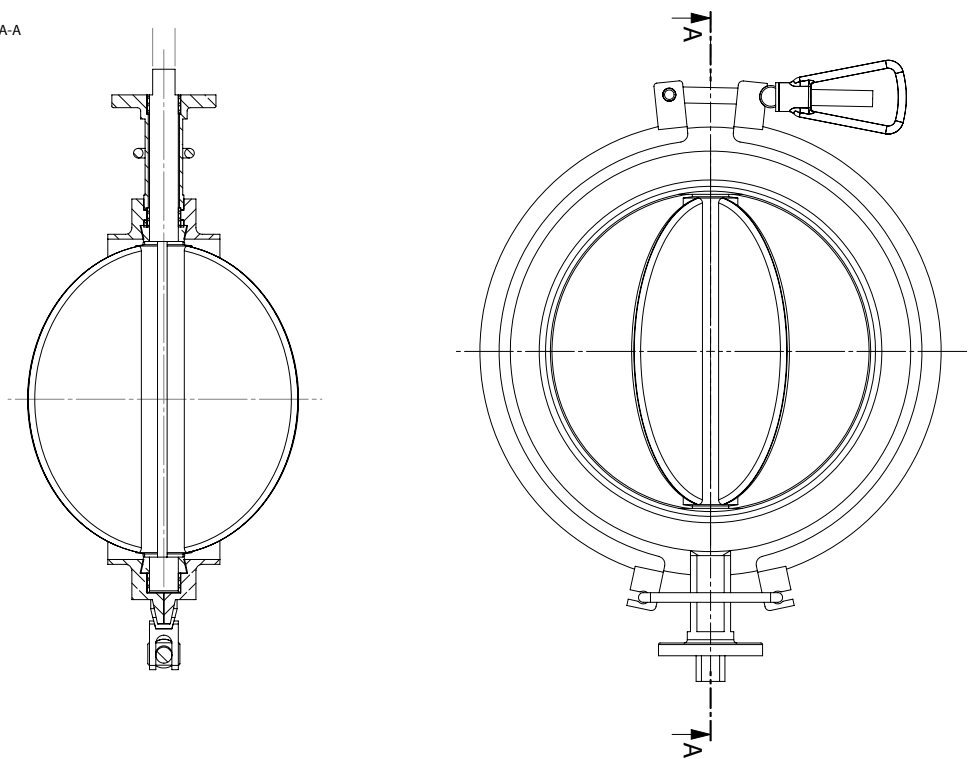

*A possible configuration*

**TYPICAL APPLICATIONS:**

Feeding of hoppers, packaging machines such as tablet presses in the pharmaceutical field  
Feeding of homogenizers in the food and chemical/cosmetic field

**MAIN FEATURES:**

- Manufactured according to cGMP and EHEDG guidelines
- Suitable for CIP and SIP

**MATERIALS:**

- Body and rotor:  
Stainless steel EN 1.4404 (AISI 316L)
- Seals:  
Translucent Silicone, EPDM, FKM (Viton®), PTFE

**MOTION DRIVE:**

- Pneumatic actuator

**DECLARATIONS AND CERTIFICATIONS:**

- FDA Certification (CFR § 177.2600)
- Material Certificate 3.1 as per EN10204
- ATEX

**SIZES:**

80	100	150	200	250	300	350	400
----	-----	-----	-----	-----	-----	-----	-----

**FINISH:**

Ra 0.5 µm internal, 1.2 µm external