

Multi-Product Brochure

An introduction to the Hanningfield product range; machinery for the processing, handling and containment of powder in manufacturing of oral solid dosage (OSD) pharmaceuticals. This includes: **Milling & Sizing, Conveying & Transfer, Lifting & Handling** and **Containment & Control**.



Company Profile

Founded in 1987, Hanningfield is an independent family-owned business. The company focuses on the design, manufacture, supply and installation of machinery for the handling, processing and containment of powder in oral solid dosage (OSD) manufacturing of pharmaceuticals.

Hanningfield manufactures the majority of equipment at the United Kingdom facility. In total, there are currently three dedicated locations across the globe:

- Hanningfield Process Systems Ltd (UK-based headquarters, serving worldwide)
- Hanningfield North America LLC (serving USA, Canada, Puerto Rico and Mexico)
- Hanningfield Asia-Pacific Pty Ltd (serving Australasia and the Asia-Pacific)

Many staff have proudly worked for the company longer than 20 years, ensuring we maintain the highest levels of workmanship and care. In-house capabilities include coded welding, fabrication, machining, polishing, assembly, electrical and testing. The company is ISO9001 certified and has been successfully audited annually since 1995, alongside various other certifications and accreditations.

What we do:



Welding



Fabrication



Machining

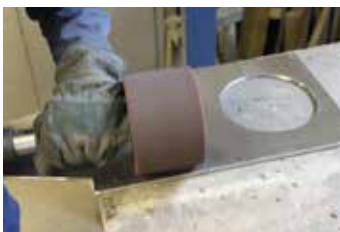

Polishing



Assembly and Testing



CAD Design

Milling and Sizing

Hanningfield offer high integrity machines for achieving various particle sizing processes.

This enables us to handle everything from bulk agglomerates to micronized material.

4 Conical Mills (Under-Driven)

6 Conical Mills (Over-Driven)

8 Lump Breakers

10 Sifters



Conical Mills (Under-Driven)

Technical Overview

Conical mills are designed for milling processes in the pharmaceutical, food, chemical and related industries. The conical mill offers numerous benefits over alternative milling methods including higher throughput, tighter particle size distribution, easier cleaning/maintenance and less noise, heat and dust. They are suitable for a wide range of applications and offer full process scalability from laboratory to pilot to production.

The Uni-Mill U-series (M05-U, M10-U, M20-U, M30-U) utilises the current industry standard under-driven conical mill design, featuring a gearbox-driven impeller, rotating inside a screen. The spacer-less design provides an optimal gap for particle size reduction in both dry and wet milling applications.

The design can be highly customised with features such as detachable mill-head, temperature monitoring, CIP, WIP, pre-breakers, nitrogen purging and ATEX execution where applicable.

Features:

- Stainless steel construction (with 316L contact parts)
- All seals FDA compliant (silicone, PTFE etc.)
- No metal-to-metal contact
- Easy-clean, GMP design (with optional features such as detachable millhead for autoclave or CIP/WIP)
- ATEX (ex-proof) versions available

Benefits:

- High throughput for maximum productivity
- Achieve various particle sizes on one machine, simply by changing screen and / or impeller
- Easy to operate
- Low heat, dust and noise generation for improved working environment
- Process scalability from lab to pilot to production
- Spacerless design for pre-set optimal milling gap
- In-line inlet and outlet for ease of process integration

Product Images



Data Table

Criteria	Unit	M05-U	M10-U	M20-U	M30-U
Max. Throughput	kgs/hr	200	400	2000	4000
	lbs/hr	425	850	4250	8800
Screen Diameter	mm	83	127	203	306
	in	3.25	5	8	12
Standard Motor	kW	0.375	1.5	4.0	7.5
	HP	0.5	2	5	10
Approx. Weight	kgs	40	140	160	400
	lbs	90	310	350	880
Standard Speed	RPM	3600	2440	1480	960
Lowest Achievable Particle Size	Approx. 150 microns (80 mesh)				
Typical Noise Level	<78dB (under factory test conditions)				
Contact Parts	AISI 316L stainless steel (1.4404)				
Non-Contact Parts	AISI 304 stainless steel (1.4301)				
Country of Design	United Kingdom				
Country of Manufacture	United Kingdom				

Typical Applications



Milling into Drum



IBC to IBC Milling



Isolator Milling



Table Top Laboratory Scale Milling



Wet Milling (Post-Granulation)



In-Line Vacuum Transfer Milling



Conical Mills (Over-Driven)

Technical Overview

The Hanningfield Uni-Mill B-Series (M10-B, M20-B, M30-B, M60-B) utilises the current industry standard over-driven conical mill design, featuring a belt-driven impeller, rotating inside a screen (60° inclusive screen angle). This principle achieves comminution by compression and shearing of the particles between the impeller and surface of the screen.

The Uni-Mill over-driven models are designed to be used with spacers, allowing customers to adjust and set the optimal gap between the screen and impeller for efficient milling (for spacer-less mills see Under-Driven Conical Mills). The Uni-Mill can be supplied with a wide-range of tooling to achieve the required final particle size and throughput. Conical mills are able to achieve size reduction as low as 150 microns (80 mesh) with minimal heat generation and are suitable for both dry and wet milling applications.

As standard, all contact parts are manufactured from 316L stainless steel (180 grit), with FDA compliant seals, gaskets etc. Non-contact parts such as frames, motor covers and control panels are manufactured from 304 stainless steel (150 grit). All standard materials of construction and surface finishes can be upgraded or downgraded upon request.

Features:

- Stainless steel construction (with 316L contact parts)
- All seals FDA compliant (silicone, PTFE etc.)
- ATEX (ex-proof) versions available

Benefits:

- Perfect for heat sensitive materials or rugged applications
- Lower noise due to belt-driven operation
- Achieve various particle sizes on one machine, simply by changing screen and / or impeller (spacers required)
- Easy to operate

Product Images



Data Table

Criteria	Unit	M10-B	M20-B	M30-B	M60-B
Max. Throughput	kgs/hr	360	1800	3600	7200
	lbs/hr	800	4000	8000	16000
Screen Diameter	mm	127	203	305	609
	in	3.25	8	12	24
Standard Motor	kW	1.5	4	7.5	15
	HP	2	5	10	20
Standard Speed	RPM	2440	1480	960	480
Approx. Weight	kgs	150	200	250	475
	lbs	330	440	250	475
Lowest Achievable Particle Size	Approx. 150 microns (80 mesh)				
Typical Noise Level	<78dB				
Contact Parts	AISI 316L stainless steel (1.4404)				
Non-Contact Parts	AISI 304 stainless steel (1.4301)				
Country of Design	United Kingdom				
Country of Manufacture	United Kingdom				

Typical Applications



**In-Line Vacuum
Transfer Milling**



Hand Feed

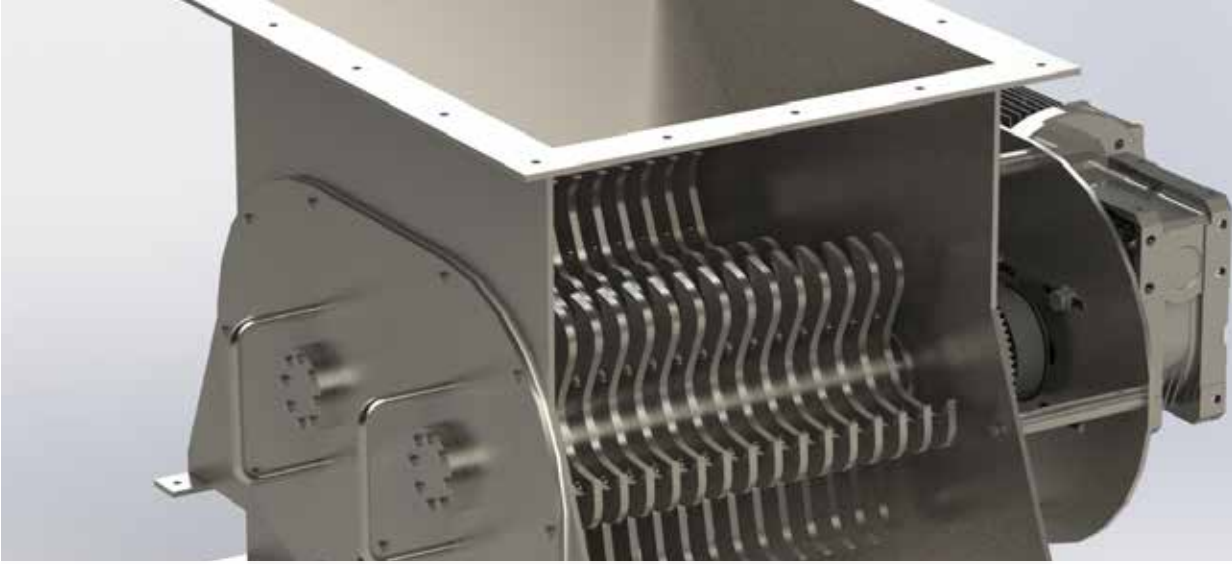

Lump Breakers

Technical Overview

The Hanningfield LumpBreaker is designed for the simple deagglomeration of compacted material into smaller particles. The lump breaker can process up to 10,000 kgs/hr (depending on application specifics) and is capable of particle size reduction down to 10mm.

Deagglomeration is typically required for any material which has compacted during storage or transportation and requires reviving prior to processing. The deagglomeration of bulk material vastly improves its flow-ability and is vital to the success of downstream processes such as milling, sieving, mixing, bagging and conveying.

The heavy duty design is available in dual-shaft execution. The cross meshed rotating breaker arms perform size reduction by cutting and shearing the material. The distance between blades can be adjusted according to the required particle size and are easily removed for maintenance or replacement.

Features:

- Stainless steel construction with FDA compliant seals
- No metal-to-metal contact
- Optional sizing grid for achieving smaller particles
- ATEX (ex-proof) versions available

Benefits:

- High throughput solution for breaking agglomerated material
- Perfect for pre-milling by reducing particle to manageable size
- Can be mounted in-line for feeding downstream process (gravity feed or vacuum transfer)
- Breaker bars can be removed for easy clean

Product Images



Data Table

Criteria	Unit	Lump Breaker
Max. Throughput	kgs/hr	Up to 10,000 kgs/hr
	lbs/hr	Up to 22,000 lbs/hr
Standard Motor	kW	2.2
	HP	3
Standard Speed	RPM	200
Inlet Size	mm	450mm x 558mm (rectangular flange with bolt holes)
Outlet Size	mm	450mm x 558mm (rectangular flange with bolt holes)
Approx. Weight	kgs	260
	lbs	570
Breaker-Arm design	Twin contra-rotating shafts with interchangeable breaker arms.	
Lowest Achievable Particle Size	Approx. 10mm (10,000µm)	
Typical Noise Level	<78dB	
Contact Parts	AISI 316L stainless steel (1.4404)	
Non-Contact Parts	AISI 304 stainless steel (1.4301)	
Country of Design	United Kingdom	
Country of Manufacture	United Kingdom	

Typical Applications



Pre-Break Before Milling



Gravity Discharge from Big Bag



Sifters

Technical Overview

The Hanningfield Kwik-Sift offers fast and effective powder screening, helping guarantee material integrity through the capture of alien objects (such as nuts, bolts, washers, cable ties). The rotating mesh drum creates a centrifugal screening action, with powder passing through the mesh while retaining those objects larger than the hole aperture. For achieving different grades of separation, various drum mesh sizes are available to meet different application requirements.

The unit can incorporate a single or dual spoiler arm arrangement for performing simple de-lumping of agglomerated material. The spoiler arm simply clamps onto the existing chute via Tri-Clover.

Features:

- Stainless steel construction (with 316L contact parts)
- All seals FDA compliant (silicone, PTFE etc.)
- Various mesh sizes available for multi-product usage
- ATEX (ex-proof) versions available

Benefits:

- Security screening at higher throughput than traditional sieving
- Suitable for delumping and deagglomeration of friable materials (with use of spoiler arm)
- Can be mounted in-line for feeding downstream process (gravity feed or vacuum transfer)

Product Images



Conveying and Transfer

Hanningfield are experts at transferring everything from powders and granules to tablets and capsules.

We can also provide a fully integrated system, managing all interfaces to deliver a complete working process.

12 Vacuum Conveyors

14 Capsule Conveyors

16 Sack Tip Stations and Feed Bins

Vacuum Conveyors

Technical Overview

The Hanningfield Uni-Vac vacuum conveyors are designed as a safe and convenient method for transferring powder. The system utilises a combination of vacuum and air (known as 'Lean-Phase' or 'Dilute-Phase') to transport powders, granules and other material. The dust-tight sealed system prevents material contamination during the transfer process, while protecting the operator, process and environment from product exposure or accidental spillage (thereby minimising waste).

The Uni-Vac hygienic 'V-Series' of vacuum conveyors (V05, V10, V20, V30, V50, V100) consists of a rolled and seam welded hopper body, which can be customised to suit any requirement. All units are assembled using clamps for fast and easy dismantling for cleaning. The crevice-free, GMP design makes it ideal for demanding applications in the pharmaceutical, food and allied industries where product integrity is vital.

The Uni-Vac is able to satisfy numerous applications including; 'suck-and-dump' and direct loading. The Uni-Vac can also be modified with optional upgrade features including level control, line clearance valves, CIP / WIP, HEPA filters, support frames and ATEX execution where applicable. All equipment can be supplied with full validation documentation (FS/DS, FAT, SAT, IQ/OQ) and 3.1 mill certificates to EN10204.

Features:

- Stainless steel construction with FDA compliant seals
- Suitable for powders, granules, flakes, pellets etc
- ATEX (ex-proof) versions available
- Optional 'stepless' design for damage-free transfer of tablets or other fragile materials

Benefits:

- Automate and accelerate loading process
- Dust-tight transfer of material from A to B
- Reduce manual handling (horizontal and vertical transfer)
- Can be mounted in-line for feeding downstream process (gravity feed or vacuum transfer)

Product Images



Data Table

Criteria	Unit	V05	V10	V20	V30	V50	V100
Max. Throughput	kgs/hr	300	900	1200	2000	3000	4000
	lbs/hr	660	2000	2650	4500	6750	9000
Hopper Diameter	mm	270	450	450	450	450	450
	in	10.6	17.7	17.7	17.7	17.7	17.7
Hopper Height	mm	600	1000	1100	1400	1600	1700
	in	23.6	39.3	43.3	55.1	63	66.9
Hopper Capacity	litres	5	10	20	30	50	100
Standard Hose Dia.	in	1.0 / 1.5	1.5	1.5 / 2.0	1.5 / 2.0	2	2.5 / 3.0
Standard Pump Size	kW	2.0	3.0	4.0	5.5	7.5	15.0
	hp	2.5	4	5	7.5	10	20
Alternative Vacuum Methods	Compressed air vacuum generator (venturi type)						
Contact Parts	AISI 316L stainless steel (1.4404)						
Non-Contact Parts	AISI 304 stainless steel (1.4301)						
Country of Design	United Kingdom						
Country of Manufacture	United Kingdom						

Typical Applications



Direct Loading (into Blender)



In-Line Vacuum Sieving



In-Line Vacuum Milling



Vacuum Transfer from Drum to Process Machine



Vacuum Transfer into a High Shear Mixer



Vacuum Transfer into a Vessel



Capsule Conveyors

Technical Overview

The Hanningfield CapsuJet capsule conveying system is a proven method for the gentle conveying of hard-shelled gelatin capsules. Designed to overcome the problems of conventional mechanical systems, the CapsuJet is ideal for the automatic loading and unloading of capsule filling machines.

The CapsuJet C20 capsule conveyors are designed for the loading of empty capsules from ground level into the capsule filling machine. The C20 is capable of loading up to 300,000 capsules per hour.

The CapsuJet FCC capsule conveyors are designed for the unloading of capsule filling machines, transferring filled capsules to a downstream container or process. The FCC can transfer up to 200,00 capsules per hour.

As standard, both capsule transfer system models are constructed with all contact parts manufactured from 316L stainless steel (180 grit), with FDA compliant seals, gaskets etc. Non-contact parts such as frames, motor covers and control panels are manufactured from 304 stainless steel (150 grit). All standard materials of construction and surface finishes can be upgraded or downgraded upon request. All equipment can be fully customised to satisfy specific application requirements and can be supplied with full validation documents (FS/DS, FAT, SAT, IQ/OQ) and mill certificates to EN10204 (3.1)

Features:

- Stainless steel construction with FDA compliant seals
- Optional level control in filling machine hopper for automating loading process.
- Hopper can be customised to accommodate extra capsules
- Very low noise levels

Benefits:

- Eliminates manual handling and ensures filling machine never 'runs dry'
- Gentle convey with virtually zero capsule damage
- Suitable for all sizes of hard shell capsule

Product Images



Data Table

Criteria	Unit	CapsuJet C20	CapsuJet FCC
Application Type	–	Transfer of Empty Capsules	Transfer of Filled Capsules
Transfer Rate	capsules/hr	300,000 *	200,000 *
Max. Vertical Convey Distance	m	10m	5m
	ft	33ft	16ft
Max. Horizontal Convey Distance	m	5m	2.5m
	ft	16ft	8ft
Standard Hopper Size	litres	200L	No hopper required
	capsules	100,000 size "0" Capsules	No hopper required
Approx Dimensions	mm	(H) 1180 x (W) 760 x (L) 1215	(H) 1150 x (W) 500 x (L) 885
	in	(H) 46 x (W) 30 x (L) 48	(H) 45 x (W) 20 x (L) 35
Approx. Weight	kgs	150	100
	lbs	330	220
Contact Parts	AISI 316L stainless steel (1.4404)		
Non-Contact Parts	AISI 304 stainless steel (1.4301)		
Country of Design	United Kingdom		
Country of Manufacture	United Kingdom		

* Note: based upon tests with size '3' Posilok capsules and sizes #5-0 Capsugel capsules

Typical Applications



Loading Empty Capsules into Encapsulation Machine



Transferring Capsules After Filling



Sack Tip Stations and Feed Bins

Technical Overview

The Hanningfield sack tip station is a simple method for the emptying of sacks, bags etc. whilst controlling the dust emissions caused during unloading. The operator lifts the bag onto the shelf of the station, piercing the bag and emptying the contents into the inlet of the downstream conveyor system. This provides a safe and contained method for the unloading of bags prior to vacuum conveying or alternative transfer methods (e.g. screw conveyors, bucket elevators). The sack-tip station incorporates a dust extraction hood to protect the operator and the process environment during emptying.

Hanningfield can also supply feed bins for the intermediate storage of powder prior to downstream processing (e.g. vacuum transfer or gravity discharge).

Features:

- Stainless steel construction (with 316L contact parts)
- Custom designs available to suit any application

Benefits:

- Enables fast, safe and easy loading of downstream process (gravity or vacuum)
- Sack tip stations can be supplied with integrated dust extraction (filter / fan)
- Feed bins can include agitator for bridge prevention

Product Images



Lifting and Handling

Hanningfield offer a wide range of systems for the lifting, blending and handling of containers and drums.

We can also offer through-floor-feeders and IBC wash stations for a complete process solution.

18 Hoists

20 Blenders

21 Drum Tippers

22 IBCs and Drums



Hoists

Technical Overview

Hanningfield Uni-Hoist lift systems are designed for the handling of containers such as Intermediate Bulk Containers (IBCs), drums, containers and bins. The lift column can also be used to manoeuvre process machinery such as vacuum conveyors, mills, lump-breakers etc.

With hundreds of installations worldwide, Hanningfield's stainless steel lift columns are engineered for safe and repeatable operation in hygienic environments. The hoist lift systems utilise either a lead-screw or chain lifting mechanism, with fail-safe features to prevent the load slipping in case of malfunction.

The hoists can be powered by electric, pneumatic or manual hand-operation. Meanwhile, the hoists can also be stationary (mounted to floor, wall, floor-to-ceiling etc.) or mobile on a trolley with castors.

The Uni-Hoist can be modified to accommodate any load type (lifting forks, clamp arm, squeeze cone, platform, hook etc.) As standard, the Uni-Hoist is manufactured from 304 stainless steel (150 grit) and is designed for use in hygienic GMP environments, with smooth surfaces and all aesthetic welds polished.

The Uni-Hoist can be supplied with full validation documentation (FS/DS, FAT, SAT, IQ/OQ) and 3.1 mill certificates to EN10204 if required.

Features:

- Stainless steel construction for use in sanitary applications
- Various power options to suit site environment (manual, electric, pneumatic)
- ATEX (ex-proof) versions available

Benefits:

- Engineered for safe and repeatable operation in hygienic environments
- Eliminate operator strain
- 'Raise, Lower, Rotate, Invert, Dock' at the push of a button
- Versatile designs for handling drums, IBCs, machines - almost anything can be lifted

Product Images



Data Table

Criteria	HES	HEM	HMS	HMM	HPS	HPM
Light Duty (SWL ≤ 250kgs)	✓	✓	✓	✓	✓	✓
Medium Duty (SWL ≤ 750kgs)	✓	✗	✗	✗	✗	✗
Heavy Duty (SWL ≤ 2000kgs)	✓	✗	✗	✗	✗	✗
Raise and Lower (of Load)	✓	✓	✓	✓	✓	✓
Inversion (of Load)	✓	✓	✓	✓	✓	✓
Rotation (of Base)	✓	✓	✓	✗	✓	✗
Power Supply	Electric (3-phase)		None / Manual		Compressed Air	
Material of Construction	AISI 304 stainless steel (1.4301)					
Country of Design	United Kingdom					
Country of Manufacture	United Kingdom					

Typical Applications



Duplex Hoist for Fast IBC Changeover



Lifting IBC above Tablet Press



Raise and Lower of Mixer



Drum Lift and Invert



Pneumatic Bowl Lifter

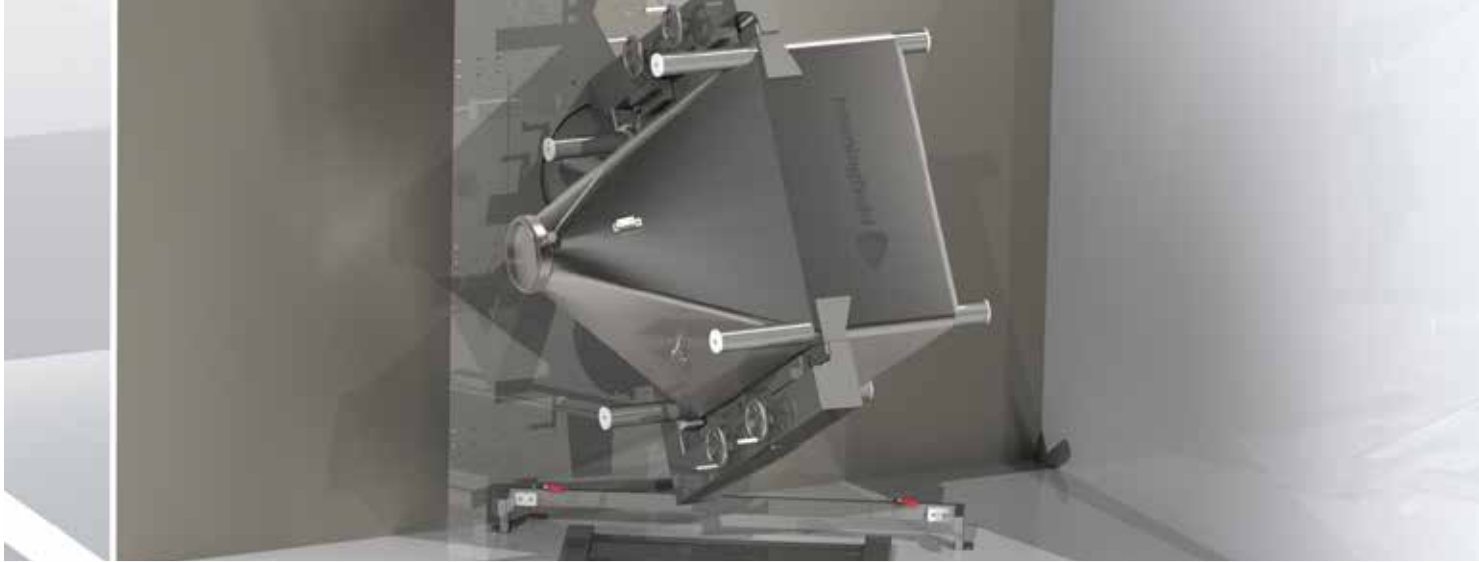

Blenders

Technical Overview

The Hanningfield Uni-Blend Bin Blenders are designed for the gentle tumbling of IBCs and drums, helping to create uniform batches. Typically, the blender is capable of handling containers up to 2000 litres capacity, with a typical maximum SWL of 1500kgs.

The bin blenders are manufactured in stainless steel and designed to conform to the GMP requirements of the pharmaceutical, food and allied industries. They are available in various executions including hoist-type, through-the-wall, fixed base and mobile.

All equipment can be supplied with full validation documentation (FS/DS, FAT, SAT, IQ/OQ) and 3.1 mill certificates to EN10204 if required.

Features:

- Stainless steel construction for use in sanitary applications
- Suitable for various container sizes, up to 2000 litres
- Can be supplied as pedestal (stand-alone), through-the-wall or post hoist mounted

Benefits:

- Maximise productivity with 'Blend-in-the-Bin', enabling immediate batch switchover without washdown
- Charging and discharging can be undertaken offline, minimising downtime
- For full compliance, controls can be supplied to meet 21 CFR Part 11

Product Images





Drum Tippers

Technical Overview

Hanningfield Drum Tippers are perfect for the manoeuvring and positioning of drums . Whether docking or simply inverting, the drum tipper will automate the process delivering a safe, accurate and repeatable action. The unit can be configured to adopt any drum size or type - and can be supplied with outlet chute or cone/valve if required.

Hanningfield Drum Tippers are manufactured in stainless steel and designed to conform to the GMP requirements of the pharmaceutical, food and allied industries. They are available in various executions including fixed base or mobile trolley.

All equipment can be supplied with full validation documentation (FS/DS, FAT, SAT, IQ/OQ) and 3.1 mill certificates to EN10204 if required.

Features:

- Stainless steel construction for use in sanitary applications
- Multi-position tipping heights available for process flexibility

Benefits:

- Eliminate manual processes and reduce operator strain
- Repeatable positioning for high integrity applications (e.g. docking to inflatable seal on isolator)

Product Images





IBCs and Drums

Technical Overview

Hanningfield are able to supply stainless steel Intermediate Bulk Containers (IBCs) for use in the pharmaceutical, food and allied industries. The containers are designed for the safe and contained transport, storage and handling of material. Typically the IBCs are supplied with a capacity of 50 litres – 2000 litres, but can be custom made to suit any process requirement or application. The IBCs can be executed in various designs, including castors for mobility, corner stacking profile and lifting loops for handling via forklift or post hoist.

Hanningfield can also supply a wide range of stainless steel drums for the contained, convenient and reusable storage of high-value powders, granules or liquids. Drums are available in various capacities from 3 litres up to 200+ litres. The drums are designed for hygienic applications with a smooth, crevice-free construction.

Features:

- Stainless steel construction with FDA compliant seals
- Various capacities and shapes available
- Custom design available (or ability to replicate existing design)

Benefits:

- Safe and contained method for storing and transporting powder
- Highly flexible, with various methods for dust-tight charging and discharging

Product Images



Containment and Control

In modern processing, the containment and control of powder is a key challenge.

Hanningfield offer cyclones for the contained capture of waste processing powder and silicone accessories for flexible contained powder transfer.

We can also provide custom containment solutions to help overcome niche problems.

24 Cyclones

26 Silicone Dust Caps

27 Silicone Connector Sleeves



Cyclones

Technical Overview

The Hanningfield Uni-Dust cyclone is specifically designed for the recovery of waste powder from pharmaceutical OSD processes such as compression and encapsulation, typically capturing between 90 – 99.9% of waste powder. We have successfully installed our cyclone to Fette, Manesty, Korsch, Zanasi, Bosch, Kilian and numerous other process machines. Where required, the cyclone can incorporate a manifold for connection to ancillary equipment such as tablet dedusters or capsule polishers.

With no filters and no moving parts, the Uni-Dust features a sanitary GMP stainless steel construction, assembled using only Tri-Clamps for fast and easy dismantling.

The Uni-Dust cyclone is proven to be equally effective in numerous other applications including sachet filling, spray drying, inhalation and any other process where excess dust is extracted. The captured waste material can be used for batch loss reconciliation, or even reintroduced to the process (where protocol permits).

Features:

- Specifically designed to be compatible with the standard airflows of compression and encapsulation machines
- GMP stainless steel construction
- Designed to be mounted inside the process room for guaranteeing integrity of captured material
- Cyclone can be retro-fitted to existing processes
- Optional manifold for collecting waste powder from deduster or polishing machine

Benefits:

- Prevents blinding and replacement of expensive filters in central dust extraction system or vacuum cleaner, with associated environmental benefits
- High efficiency design, typically capturing 90 - 99.9%
- Almost zero maintenance costs, as cyclone has no moving parts and no filters
- Helps pharmaceutical manufactures comply with FDA guidelines on batch reconciliation and yields
- Where protocol permits, recovered powder can be re-worked and re-introduced, minimising material loss

Product Images



Data Table

Criteria	Unit	Type 5	Type 10	Type 20	Type 30	Type 40	Type 50	Type 60
Airflow Range	m ³ /hr	100 – 150	150 – 250	250 – 300	300 – 400	400 – 600	600 – 800	800 – 1200
	CFM	59 – 88	88 – 147	147 – 177	177 – 235	235 – 350	350 – 470	470 – 700
Cyclone Body Dia.	mm	101.6	139.7	152.4	168.2	203.2	254	304.8
	in	4" T/C	5½" T/C	6" T/C	6½" T/C	8" T/C	10" T/C	12" T/C
Inlet / Outlet Pipe Dia.	mm	50.8	63.5	63.5	76.2	101.6	127	139.7
	in	2" T/C	2½" T/C	2½" T/C	3" T/C	4" T/C	5" T/C	5½" T/C
Product Discharge Dia.	mm	63.5	101.6	101.6	101.6	139.7	168.2	203.2
	in	2½" T/C	4" T/C	4" T/C	4" T/C	5½" T/C	6½" T/C	8" T/C
Approximate Weight	kgs	12	18	22	34	40	52	68
	lbs	26	40	50	75	90	115	150
Typical Noise Level	dB	0 dB (no moving parts / no mechanical noise generated)						
Contact Parts	AISI 316L stainless steel (1.4404)							
Non-Contact Parts	AISI 304 stainless steel (1.4301)							
Country of Design	United Kingdom							
Country of Manufacture	United Kingdom							

Typical Applications



Dust Collection from Tablet Press



Dust Collection from Capsule Filling Machine



Silicone Dust Caps

Technical Overview

The Hanningfield Uni-Cap is a flexible silicone rubber seal which provides a cost-effective method for the dust-tight transfer or containment of powders.

By cutting a hole in the centre of the cap, a dust-tight seal can be made with the penetrating spigot. This enables the contained charging of mills, tablet presses, vessels, drums / IBCs etc.

Product Images



Data Table

Dust Caps

Criteria	Unit	2.5"	5"	8"	8" T/C	10"	12"	16"
Diameter	mm	60mm	127mm	200mm	200mm	250mm	315mm	400mm
	in	2.5"	5"	8"	8"	10"	12"	16"
Height	mm	33mm	35mm	40mm	25mm	36mm	32mm	32mm
Wall Thickness	mm	8mm	10mm	10mm	10mm	10mm	9.5mm	9.5mm
Material Hardness	shore	60	60	60	60	60	60	60
Max. Spigot Size	mm	50mm	100mm	150mm	150mm	200mm	265mm	350mm
Part Number		736564	736584	736571	736561	736565	736567	736572
Standard Material	Translucent Silicone (FDA CFR 177.2600)							

Mounting Rings

Criteria	Unit	2.5"	5"	8"	8" T/C	10"	12"	16"
Outside Diameter	mm	60mm	127mm	204mm	N/A	250mm	318mm	404mm
Height	mm	50mm	50mm	N/A	50mm	50mm	50mm	32mm
Wall Thickness	mm	2mm	2mm	2mm	N/A	2mm	2mm	2mm
Part Number		735688	750406	735689	N/A	735690	735691	735692
Standard Material	316L stainless steel (1.4404)							



Silicone Connector Sleeves

Technical Overview

The Hanningfield Uni-Connect range of silicone compensator sleeves are designed to provide quick and hygienic connection for dust tight powder transfer between interfaces, which can easily compensate for misalignment between process machines.

Available in 2", 4", 6", 8", 10" and 12", the Uni-Connect is designed to be compatible with a standard Tri-Clover profile.

Product Images



Data Table

Criteria	Unit	2"	4"	6"	8"	10"	12"
Diameter	in	2"	4"	6"	8"	10"	12"
Length	mm	40mm	40mm	50mm	50mm	60mm	70mm
Wall Thickness	mm	1.6mm	2.4mm	2.0mm	2.0mm	2.0mm	2.0mm
Material Hardness	shore	70	70	70	70	70	70
Operating Pressure	barg	0.8	0.8	0.8	0.5	0.5	0.5
	psi	11.6	11.6	11.6	7.25	7.25	7.25
Max Pressure	barg	4.0	2.5	2.5	1.0	1.0	1.0
	psi	58	3.6	3.6	14.5	14.5	14.5
Operating Vacuum	barg	0.5	0.5	0.5	0.5	0.5	0.5
	psi	7.25	7.25	7.25	7.25	7.25	7.25
Min. Operating Temperature	°C	-20°C					
	°F	-50°F					
Max. Operating Temperature	°C	+140°C					
	°F	+289°F					
Standard Material	Translucent Silicone (FDA CFR 177.2600)						

hanningfield



UK and Worldwide (Headquarters)

Hanningfield Process Systems Ltd
17 Millhead Way
Purdeys Industrial Estate
Rochford, Essex
SS4 1LB
United Kingdom

Tel: +44 (0) 1702 549 777

Fax: +44 (0) 1702 549 888

E-Mail:

sales@hanningfield.com

USA, Canada, Mexico and North America

Hanningfield (North America) LLC
PO Box 1178
Hillsborough
North Carolina
27278
United States of America

Tel: +1 (919) 338 2884

E-Mail:

northamerica@hanningfield.com

Australasia and the Asia-Pacific

Hanningfield (Asia-Pacific) Pty Ltd
PO Box 362
Kenmore
Queensland
4069
Australia

Tel: +61 (0) 488 242158

E-Mail:

pacific@hanningfield.com

www.hanningfield.com