



Conical Mills (Under-Driven)

Sanitary size reduction milling machines for dry and wet processes in the pharmaceutical, food and related industries. Suitable for laboratory, pilot and full-scale production applications.



**Before and after image of pharma-grade lactose milled on Hanningfield Uni-Mill.
After milling, material passed through a 250 micron sieve (with 0% retention).**

Product Overview

Conical mills are designed for milling processes in the pharmaceutical, food, chemical and related industries. The conical mill offers numerous benefits over alternative milling methods including higher throughput, tighter particle size distribution, easier cleaning/maintenance and less noise, heat and dust. They are suitable for a wide range of applications and offer full process scalability from laboratory to pilot to production.

The Uni-Mill U-series (M05-U, M10-U, M20-U, M30-U) utilises the current industry standard under-driven conical mill design, featuring a gearbox-driven impeller, rotating inside a screen. This principle achieves comminution by compression or shearing of the particles between the impeller and surface of the screen.

The Uni-Mill under-driven models are designed with an optimal, spacer-less gap (to avoid metal-to-metal contact); this offers a major benefit compared with over-driven conical mills where the distance between the screen and impeller has to be set manually using spacers. This makes tooling changes on under-driven mills faster and easier, guaranteeing the closest possible gap every time. Other benefits include a more compact design, improved sanitary construction and in-line inlet and outlet offering higher throughput

Hanningfield mills offer excellent flexibility and are available with a wide-range of screen and impeller tooling, helping to achieve the various required final particle sizes and throughputs. Conical mills are typically suitable for size reduction down to approximately 150 microns (80 mesh) with minimal heat generation and are suitable for both dry and wet milling applications.

As standard, all contact parts are manufactured from 316L stainless steel, with FDA compliant seals, gaskets etc. Non-contact parts such as frames, motor covers and control panels are manufactured from 304 stainless steel. All standard materials of construction and surface finishes can be upgraded or downgraded upon request.

The Hanningfield Uni-Mill is highly customisable and can be supplied mounted to mobile frame, swing-arm, height-adjustable hoist or freestanding. The inlet and outlet can be configured with options such as hand feed chute, valves, tri-clovers, vacuum adaptors or any bespoke design required for process integration

The design can be further modified with features such as detachable mill-head, temperature monitoring, CIP, WIP, pre-breakers, nitrogen purging and ATEX execution where applicable. All equipment can be supplied with full validation documentation (FS/DS, FAT, SAT, IQ/OQ) and 3.1 mill certificates.

Features:

- Stainless steel construction (with 316L contact parts)
- All seals FDA compliant (silicone, PTFE etc.)
- No metal-to-metal contact
- Easy-clean, GMP design (with optional features such as detachable millhead for autoclave or CIP/WIP)
- ATEX (ex-proof) versions available

Benefits:

- High throughput for maximum productivity
- Achieve various particle sizes on one machine, simply by changing screen and / or impeller
- Easy to operate
- Low heat, dust and noise generation for improved working environment
- Process scalability from lab to pilot to production

Models

Uni-Mill M05-U

The Uni-Mill M05-U is designed for laboratory and small scale applications. The unit features an 83mm diameter screen (3.25"), enabling throughputs up to ~200kgs/hr (425 lbs/hr).

The M05-U features an 8" feed chute with 6" outlet (note: inlet / outlet configuration can be modified to suit any application requirement). The unit is supplied with a 0.375kW motor set to a standard speed of 3600RPM (includes variable speed drive as standard).

Uni-Mill M10-U

The Uni-Mill M10-U is designed for pilot or low capacity applications. The unit features an 127mm diameter screen (5"), enabling throughputs up to ~400kgs/hr (850 lbs/hr).

The M10-U features a 10" feed chute with 8" outlet (note: inlet / outlet configuration can be modified to suit any application requirement). The unit is supplied with a 1.5kW motor set to a standard speed of 2440RPM (optional variable speed drive available).

Uni-Mill M20-U

The Uni-Mill M20-U is designed for a wide scope of production applications. The unit features an 203mm diameter screen (8"), enabling throughputs up to ~2000kgs/hr (4250 lbs/hr).

The M20-U features a 12" feed chute with 12" outlet (note: inlet / outlet configuration can be modified to suit any application requirement). The unit is supplied with a 4.0kW motor set to a standard speed of 1480RPM (optional variable speed drive available).

Uni-Mill M30-U

The Uni-Mill M30-U is designed for high capacity production applications. The unit features an 306mm diameter screen (12"), enabling throughputs up to ~4000kgs/hr (8800 lbs/hr).

The M30-U features a 12" feed chute with 500mm v-clamp connection on the outlet (note: inlet / outlet configuration can be modified to suit any application requirement). The unit is supplied with a 7.5kW motor set to a standard speed of 960RPM (optional variable speed drive available).

Trial Facility

For peace of mind we invite customers to undertake trial milling of their material free of charge at our UK test facility (with optional attendance). Trials can help determine machine size for achieving throughput and identify appropriate tooling for realising the required particle size.

Data Table

Criteria	Unit	M05-U	M10-U	M20-U	M30-U
Max. Throughput	kgs/hr	200	400	2000	4000
	lbs/hr	425	850	4250	8800
Screen Diameter	mm	83	127	203	306
	in	3.25	5	8	12
Standard Motor	kW	0.375	1.5	4.0	7.5
	HP	0.5	2	5	10
Approx. Weight	kgs	40	140	160	400
	lbs	90	310	350	880
Standard Speed	RPM	3600	2440	1480	960
Lowest Achievable Particle Size	Approx. 150 microns (80 mesh)				
Typical Noise Level	<78dB (under factory test conditions)				
Contact Parts	AISI 316L stainless steel (1.4404)				
Non-Contact Parts	AISI 304 stainless steel (1.4301)				
Country of Design	United Kingdom				
Country of Manufacture	United Kingdom				





Attention to Detail

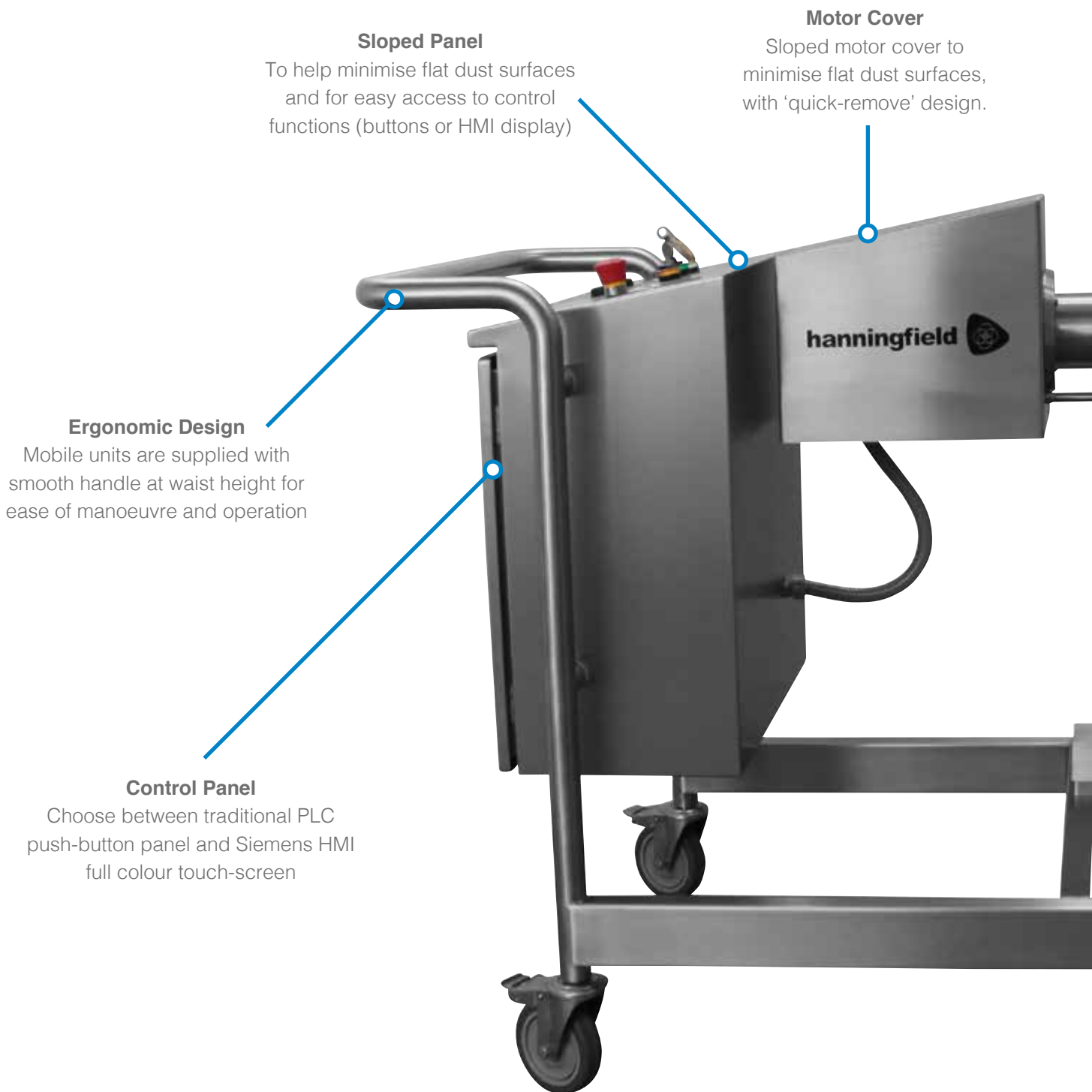

Sloped Panel

To help minimise flat dust surfaces and for easy access to control functions (buttons or HMI display)

Motor Cover

Sloped motor cover to minimise flat dust surfaces, with 'quick-remove' design.

Ergonomic Design

Mobile units are supplied with smooth handle at waist height for ease of manoeuvre and operation

Control Panel

Choose between traditional PLC push-button panel and Siemens HMI full colour touch-screen

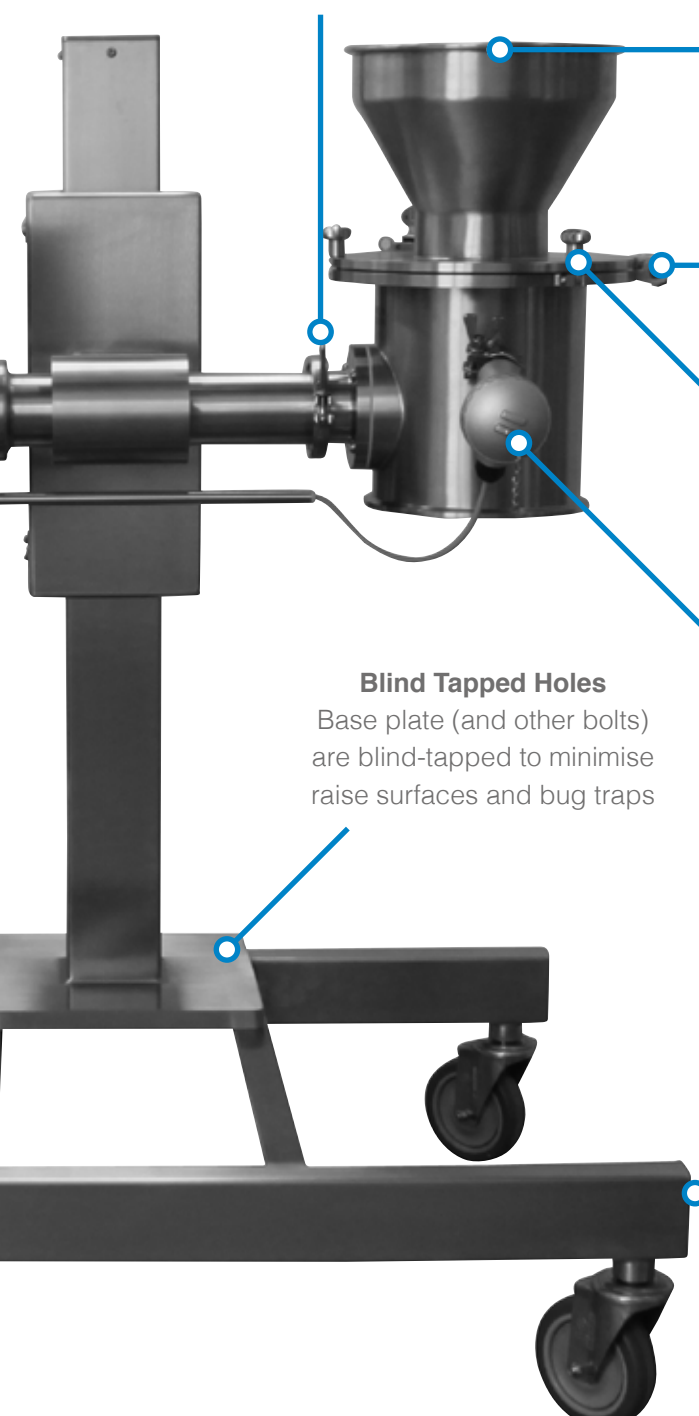

Autoclave Adaptor Kit (Optional)

Tri-clover connection on arm for quick removal of machine mill-head for cleaning

Inlet Options

Hand-feed chute, tri-clover connections, silicone cap mounting ring, vacuum adaptors or any bespoke design required for process integration

Interlock Options

Various options including Castell Key for wireless mechanical interlocking, magnetic switches, time-delay bolts etc.

Swing Bolts

Concealed head stainless steel swing bolts with smooth head, and ergonomic hand grip

Blind Tapped Holes

Base plate (and other bolts) are blind-tapped to minimise raise surfaces and bug traps

Temperature Monitoring (Optional)

Spring-loaded PT100 thermocouple, with probe located against mill screen to monitor surface temperature increases which may affect product quality or process safety

Frame

Various options including mobile trolley with box section frame or optional curved profile for improved GMP. Other options include swing-arm, post hoist, fixed post or supplied freestanding.

Typical Applications



Milling into Drum

The conical mill can be hand-fed allowing immediate discharge into the drum below (various methods of dust containment are available).



IBC to IBC Milling

By positioning a bin above the mill, and another bin below the mill, product is released from the top IBC, milled, and then passes directly into the bottom IBC.



Isolator Milling

The Uni-Mill is suitable for isolator integration using our 'through-the-wall' design. This mounts the milling head inside the isolator, whilst keeping motor and controls external.



Table Top Laboratory Scale Milling

The Uni-Mill M05-U is suitable for table-top use, such as those performed in R&D or lab scale applications. Product can be milled into bags, drums etc (containment available).



Wet Milling (Post-Granulation)

Milling after granulation increases the surface area of the material. This enables a faster, more consistent drying process downstream.



In-Line Vacuum Transfer Milling

The Uni-Mill can be integrated with vacuum transfer systems for the automated loading or unloading of process machinery, with in-line conical milling (example application: unloading a fluid bed dryer).

Tooling

Screens

A wide range of screens are available for satisfying the required particle size across nearly all milling applications.

Screens are available with a wide range of hole sizes, and the following hole shapes: Round, Square, Slotted, Grater and Conidur hole.



Impellers

A wide range of impellers are also available, for providing the right milling action (e.g. maximising throughput or minimising fines).

Impellers are available with the following arm profiles: round-bar, square-bar, bevel-bar, reverse bevel bar. We can also engineer custom impeller shapes upon request



Spare and Care Kit

The Hanningfield Uni-Mill range can be supplied with a 'Spare and Care Kit' covering all your planned (and unplanned) maintenance requirements.

The spares and maintenance tools are supplied in a hard-shell carry case with part-specific foam inserts (complete with dual layer, two-tone black / blue foam for easy identification of missing parts).



hanningfield



UK and Worldwide (Headquarters)

Hanningfield Process Systems Ltd
17 Millhead Way
Purdeys Industrial Estate
Rochford, Essex
SS4 1LB
United Kingdom

Tel: +44 (0) 1702 549 777
Fax: +44 (0) 1702 549 888

E-Mail:
sales@hanningfield.com

USA, Canada, Mexico and North America

Hanningfield (North America) LLC
PO Box 1178
Hillsborough
North Carolina
27278
United States of America

Tel: +1 (919) 338 2884
Fax: +44 (0) 1702 549 888

E-Mail:
northamerica@hanningfield.com

Australasia and the Asia-Pacific

Hanningfield (Asia-Pacific) Pty Ltd
PO Box 362
Kenmore
Queensland
4069
Australia

Tel: +61 (0) 488 242158
Fax: +44 (0) 1702 549 888

E-Mail:
pacific@hanningfield.com

www.hanningfield.com